



Gore Membrane Vents

POV/Snap-Fit

Membrane Characteristic

Hydrophobic and Oleophobic
Oil Rating 3 (AATCC 118-1997ASTM)
Water entry pressure of the membrane ≥ 0.6 bar/60 sec

Ingress Protection class of the installed

POV/Snap-Fit

IP65 - Water jets
IP67 - 1 meter water submersion for 30 minutes
IP69K - High pressure spray

Temperature Resistance

(DIN IEC 68-2-14, Na)
Cycle test Cycles 400
T_{dwell}=20 min, t_{change}<10 sec.
POV/Snap-Fit vents are designed for service temperature range of -40°C to 125°C.

UV and Climate Resistance

Industrial climate test (DIN 50-0-18) Test criteria SFW 2.0 S
Cycle 9
UV and climate resistance: other than a little yellowing of the top surface, no significant change in mechanical characteristics.

Salt Spray Test (DIN 50-0-21)

No penetration of salt crystals through the membrane into the housing.

Design and Dimensions

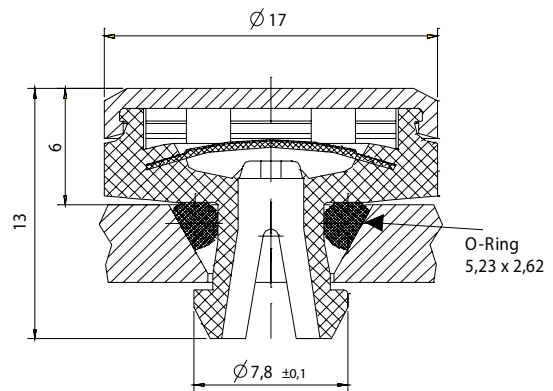

Recommended Installation

